

AIRGO® 2.0

Big Ass Fans' unrivaled air superiority brings its ground game.

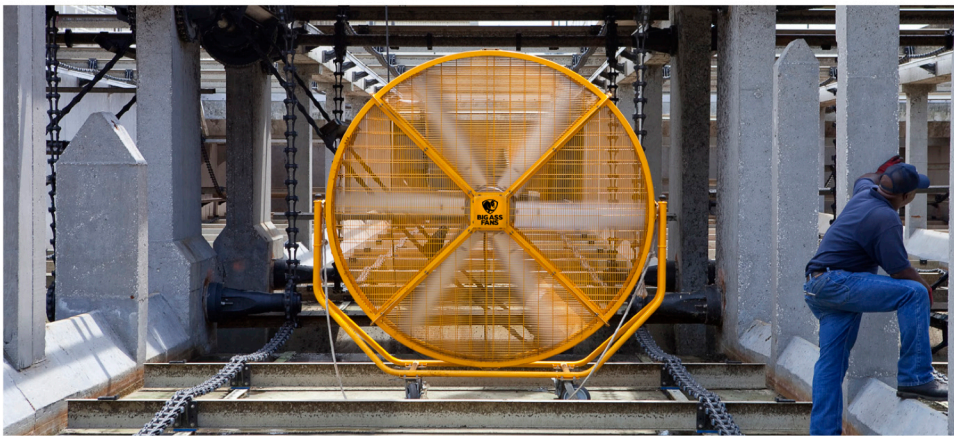
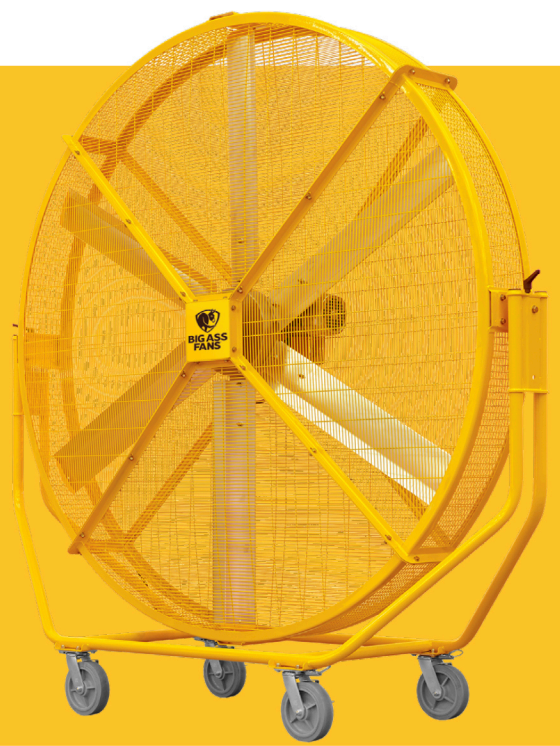

BUILT FOR THE DAILY GROUND AND POUND

Our largest mobile fan, AirGo 2.0 uses the same high-volume, low-speed (HVLS) technology as our overhead fans to deliver huge amounts of airflow with energy-efficient performance. With a direct-drive motor, AirGo 2.0 operates at a whisper, not a roar. Use it both indoors and out to keep people cool and comfortable and odors, pests, and heat at bay. Setup is simple—just attach casters and it's ready to roll for portable cooling that can be felt up to 120 feet (36.6 meters) away!

COMMON APPLICATIONS FOR AIRGO 2.0:

- ✓ Recreational and fitness spaces
- ✓ Mobile work zones
- ✓ Large, open spaces
- ✓ Long corridors and dock doors
- ✓ Low ceiling height areas
- ✓ Outdoor events and festivals

Key Features

- ✓ 8-foot (2.4-m) diameter provides cooling air movement across a large area
- ✓ Efficient direct-drive motor offers variable speeds
- ✓ Easy to clean; IPX5 rated for indoor or outdoor use
- ✓ OSHA-compliant cage guarantees worry-free cooling
- ✓ Optional All Terrain Package
- ✓ 5-year warranty (varies by country; see complete warranty for details)

AIRGO 2.0

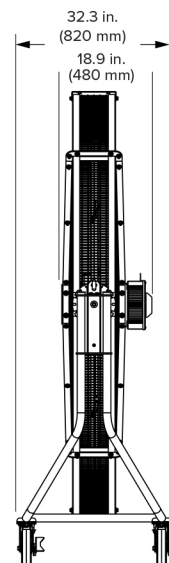
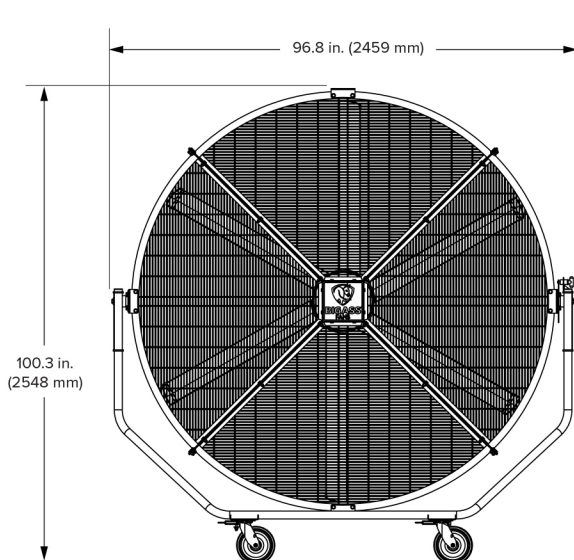
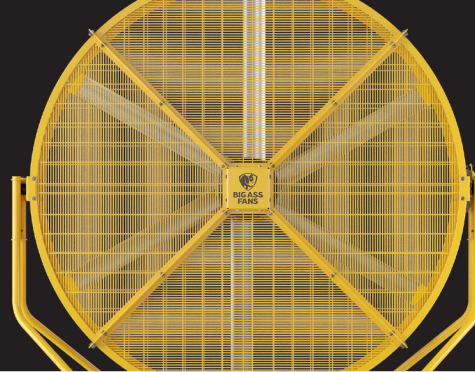

AIR. ON THE GO. NOW!



Technical Specifications

Input power and required breaker	Amperage	Wattage	Operating Temperature	Sound at max speed ¹	Weight
110–125 VAC, 50/60 Hz, 1 Φ, 15 A	7.7–7.0 A	481 W	-4°F to 131°F (-20°C to 55°C)	64 dBA	425 lb (193 kg)
200–240 VAC, 50/60 Hz, 1 Φ, 10 A	5.6–4.7 A	469 W			

Construction Features

Cage and Frame	Motor and Controller	Power Supply	Environment	Certifications	Colors	Accessories
Preassembled 8 ft (2.4 m) steel frame OSHA-compliant cage	Direct drive ECM motor Variable speed control	25 ft (7.6 m) cord with plug fits standard power outlet Optional 10 ft (3 m) cord available	IPX5 for indoor or outdoor use Washdown construction	 UL Standard 507 and CSA Standard 22.2 No. 113 	Yellow or white Custom colors available	All Terrain package includes oversized, foam-filled tires

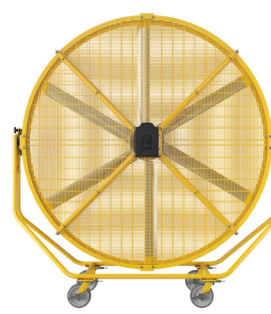
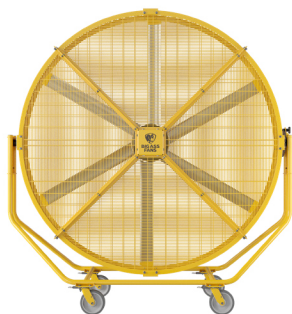

¹ Not suitable for salt air environments.

² Fans are sound tested at maximum speed in a laboratory environment. Actual results in field conditions may vary due to sound reflecting surfaces and environmental conditions.

Lead times may vary. See full warranty for coverage information.

AIRGO 2.0

AIRFLOW

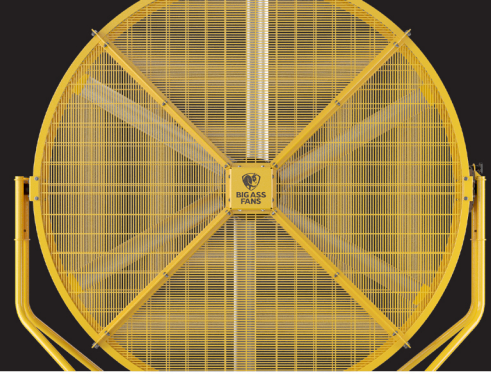

AIRFLOW VELOCITY

The three lines show air velocity from the center of the fan at three sensors of varying height.

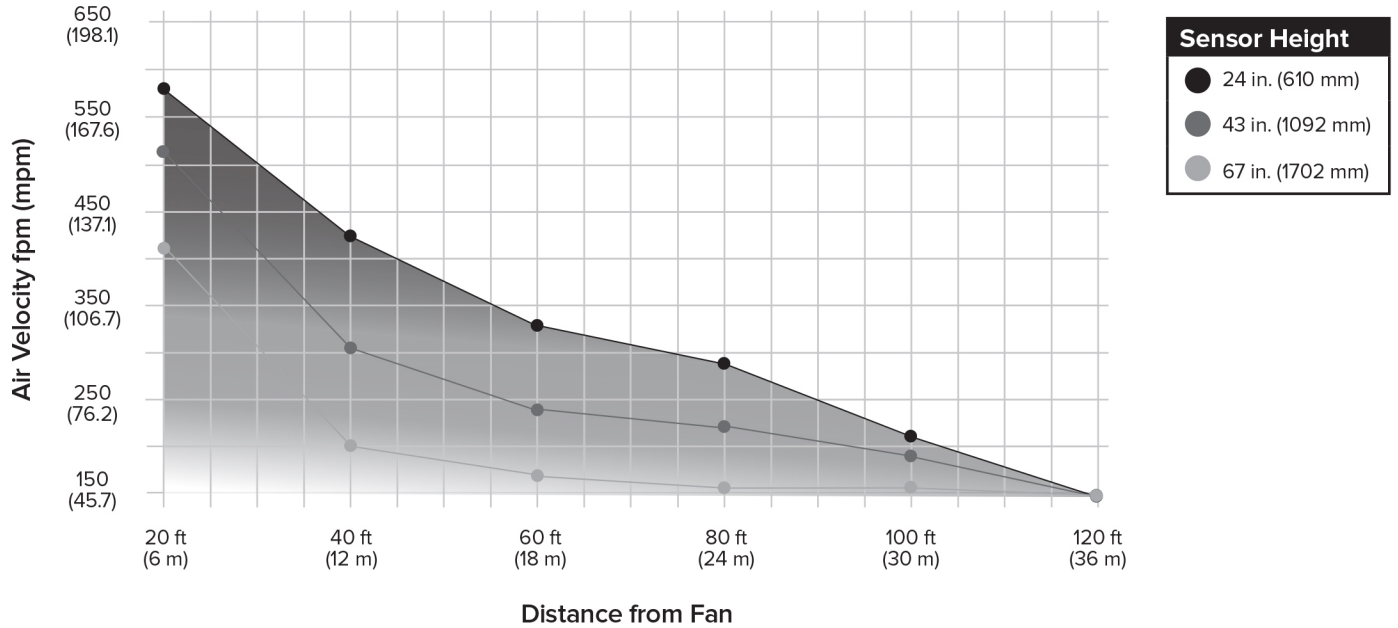

AIRFLOW DISTANCE

Shaded areas represent cooling up to 120 feet (36.6 meters). That's one-third the length of a football field! Darker shading indicates faster air velocity.

